

HG3Z1014AFCS

3X 10mm - 30mm F1.4
for 1/2" Format Cameras, Vari-focal Auto Iris VIDEO Drive
CS-Mount

with Focus and Amplifier

Model No.	HG3Z1014AFCS		Effective	Front	Ø26.6mm		
Focal Length	10mm - 30mm		Lens Aperture	Rear	Ø9.0mm		
Max. Aperture Ratio	1:1.4		Back Focal	Tele	9.8mm		
Max. Image Format	6.4mm x 4.8mm(Ø8mm)		Length	Wide	11mm		
Operation Range	Iris	F1.4 - F360C	Flange Back Length	12.5mm			
	Focus	0.6m - Inf.	Mount	CS-Mount			
	Zoom	10mm - 30mm	Filter Size	M37.5 P=0.5mm			
Control	Iris	Auto Iris	Dimensions	Ø41.7mm x 57.5mm x 57.7mm			
	Focus	Manual	Weight	130g			
	Zoom	Manual					
Object Dimension at M.O.D.	10mm	38.8cm x 28.6cm					
	30mm	13.1cm x 9.9cm					
Angle of View	D	1/2"	44.8° - 15.6°	1/3"	35.6° - 11.7°	1/4"	25.1° - 8.8°
	H		35.8° - 12.5°		26.8° - 9.4°		20.1° - 7.0°
	V		26.8° - 9.4°		20.1° - 7.1°		15.0° - 5.3°
Supply Voltage	DC8.5V - DC16V						
Current	Less than 40mA						
Response Time	Approx. 2 sec.						
Light Weighting Method	Adjustable between Average - Peak (to be Set at Average at Factory)						
Input Signal	Video Signal (V. or V.S.)						
Iris Accuracy	± 15% at Video Signal Level						
Sensitivity Adjustment	0.5V(p-p) - 1.0V(p-p) (Video Signal)						
Input Impedance	High Impedance						
Operating Temperature	-20°C - +50°C						

1/2"

CS

M.O.D. : Minimum Object Distance

Dimensions

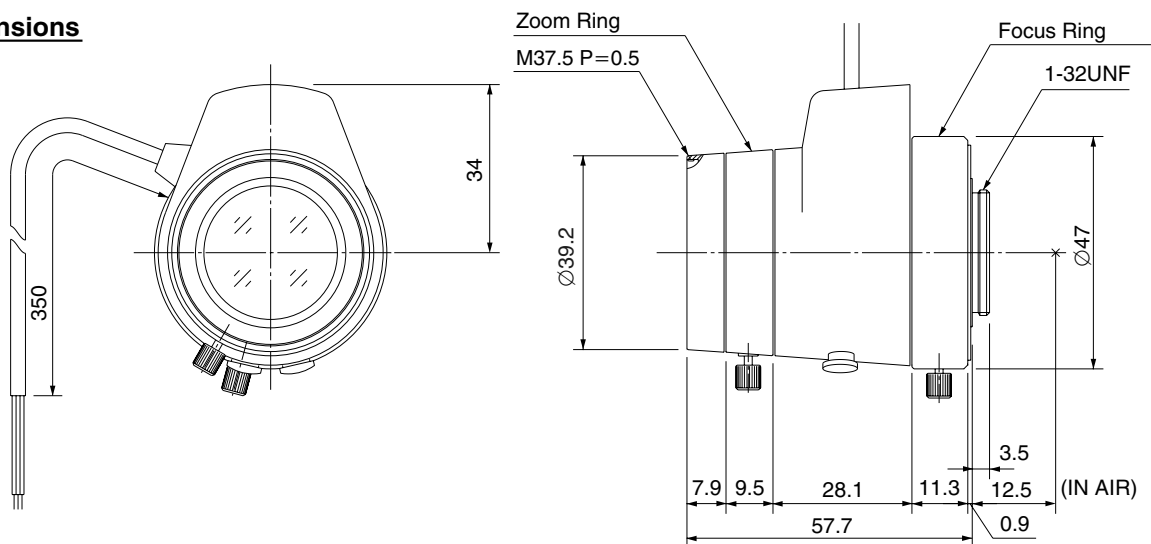

Wiring Diagram

